

ANTHONY LIFTGATES, INC.

INSTALLATION AND OPERATION MAINTENANCE & TROUBLESHOOTING

For AST and ATU Model Tuckunder Liftgates

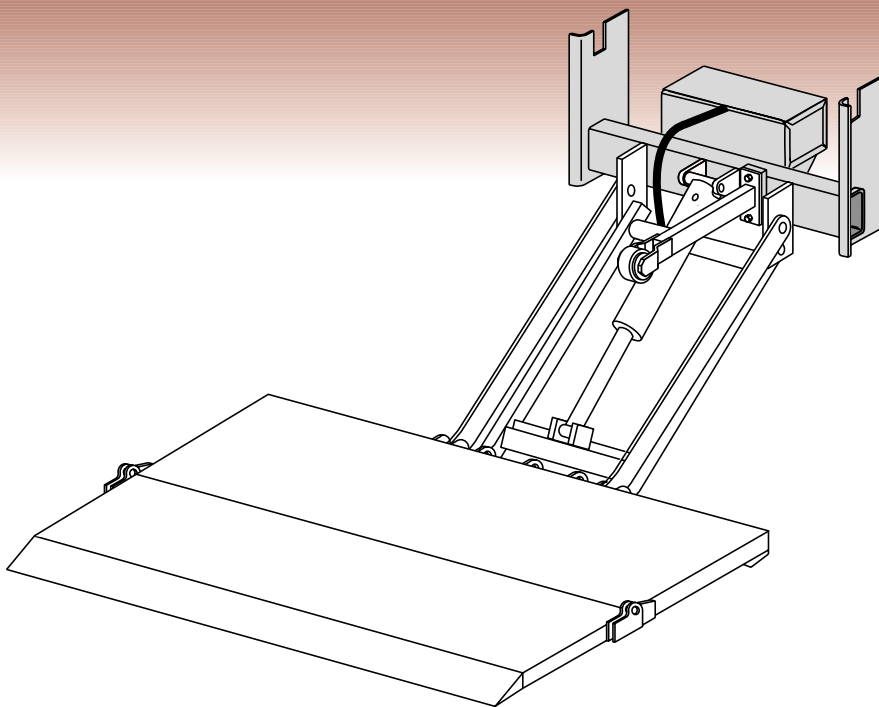

MODELS

AST-1500-SF

AST-2000-SF

AST-2500-SF

AST-3000-SF

ASTL-1800-SF

ASTL-2500-SF

ATU-1800-SF

ATU-2500-SF

ATU-3000-SF

ATU-3500-SF

ATU-1800LB-SF

ATU-2500LB-SF

ANTHONY
LIFTGATES, INC.®

Anthony Liftgates, Inc.

1037 W. Howard Street • P.O. Box 615 • Pontiac, IL 61764-0615

Ph: 815.842.3383 • Fax: 815.844.3612 • Toll Free: 800.482.0003

www.anthonyliftgates.com

Contents

General Information Section

Introduction	2
Nomenclature	4
General Information	5

Installation Section

General Installation Information	6
Installation Procedure	9
Final Inspection Checklist	22
Decals	23

Operation Section

General Safety Operating Instructions	28
Operating Instructions	30

Maintenance Section

Quick Check Maintenance Guide	31
Maintenance Procedures	32
Platform Adjustment (adding shims)	32
Checking the Control Switch	32
Checking Motor Start Solenoid and Power Cut-off Solenoid	33
Checking Battery Cable	34
Checking Lowering Valve Cartridge and Solenoid	34
Checking Cylinder Piston Seals	35
Checking and Adjusting System Pressure	36
Flow Control Valve	37

Safety Section

Safety	38
------------------	----

Troubleshooting Section

Troubleshooting Guide	42
---------------------------------	----

General Information Section

Introduction

Congratulations on selecting an Anthony Liftgates Tuckunder liftgate. Anthony liftgates are among the finest liftgates available on the market today. To ensure your liftgate will perform to your expectations we have provided the following manuals, designed to provide you with the necessary instructions and safety precautions to install and operate the Tuckunder models of Anthony liftgates.

1. Installation, Operation, Troubleshooting, and Maintenance manual for AST and ATU Model Tuckunder Liftgates - Form No. TU-IO-08/00
2. Parts manual for AST and ATU Model Tuckunder Liftgates - Form No. TU-P-08/00

This Installation, Operation, and Maintenance manual will provide you easy to follow instructions, along with photos and illustrations. We have included a series of Tips, which will facilitate the installation process. All Safety precautions have been clearly identified and detailed throughout each section.

In addition, a complete explanation of the safety words and rules are included in the Safety section on page 38 of this manual. Please turn to this section and read thoroughly before proceeding to the next page.

At the bottom of each page is the Anthony Liftgates Inc. Product Support phone number. If you are unclear about any of the instructions, please phone Anthony Liftgates' Product Support.

All Anthony Tuckunder model liftgates are factory assembled, tested, and energized to assure the highest quality performance standards. AST and ATU liftgates ship completely assembled on skids for fast, clean, and easy installation.

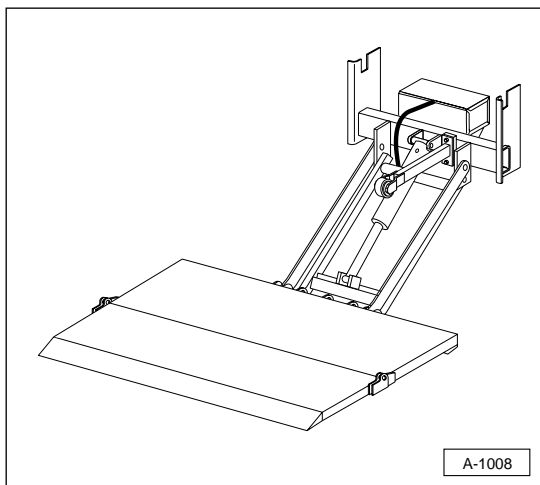

Typical Anthony Liftgates Tuckunder liftgate.

Even though the following goes without saying, we feel compelled to state:



Anthony liftgates should only be installed by those with sufficient skills to understand the installation and operation of the liftgate, along with the equipment required to install the liftgate. The installation instructions in this manual are intended to give typical installation instructions to the installer for both the operation and what we believe to be the most desirable sequence of installation. These instructions cannot replace a qualified person, or clear thinking and the basic knowledge that must be possessed by the installer.

We urge the installer (or anyone else) to call us if they have any questions. We have qualified personnel at our Pontiac, Illinois, plant to answer any questions that you may have. A detailed discussion on the phone can be far more satisfactory than a detailed written explanation.

It has been our experience that a knowledgeable journeyman following these installation instructions and observing the operation of the liftgate will have sufficient comprehension of the liftgate to enable this person to troubleshoot and correct all normal problems that may be encountered. However, again we urge you to call us at the Pontiac, Illinois, plant if you find the liftgate is not operating properly or if you do not know how to make the necessary repair.

If you have any doubts or questions, call us at:

Anthony Liftgates, Inc.
1037 West Howard Street
Pontiac, Illinois 61764
(815) 842-3383
www.anthonyliftgates.com

 DANGER	
	The success or failure of this liftgate to properly and efficiently operate will depend on a thorough and proper installation. Failure to read, understand, and follow the installation instructions and safety recommendations in this manual before installing the liftgate can result in serious injury or death. Also read and understand the operating instructions in the Operation section.
When installed, this liftgate must not alter nor prevent vehicle compliance to any existing state or federal standards, and especially FMVSS 105. Each chassis manufacturer's recommendations should be consulted for compliance. Also make sure the weight of the liftgate and its load will not overbalance the truck, possibly raising the front wheels off the ground.	

Nomenclature

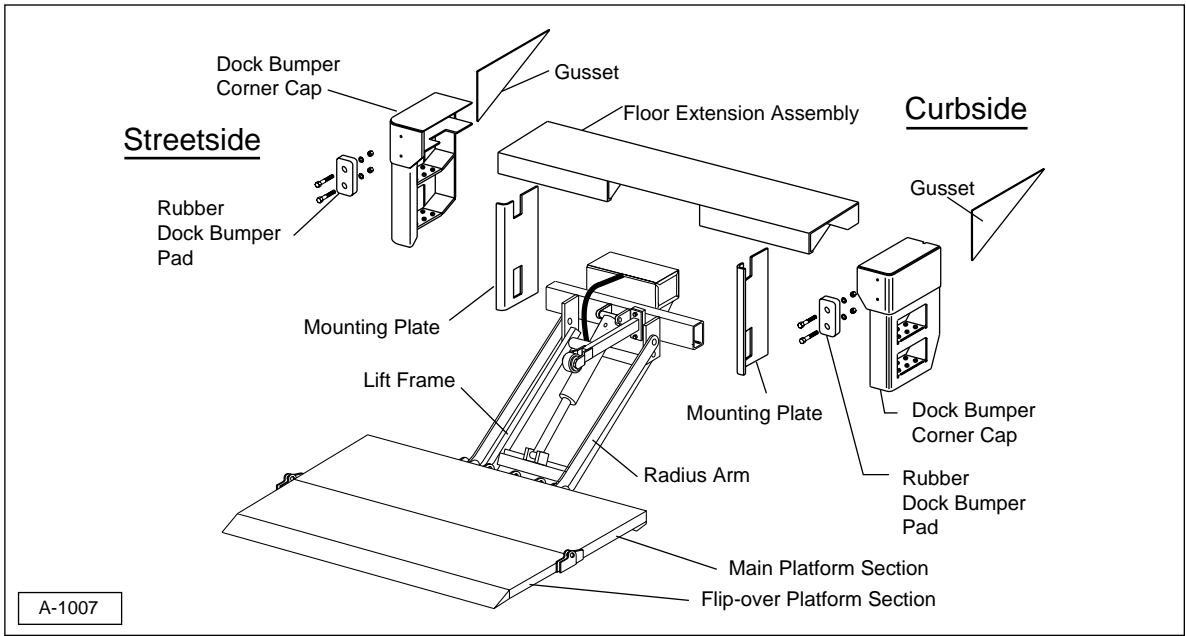

Platform nomenclature.

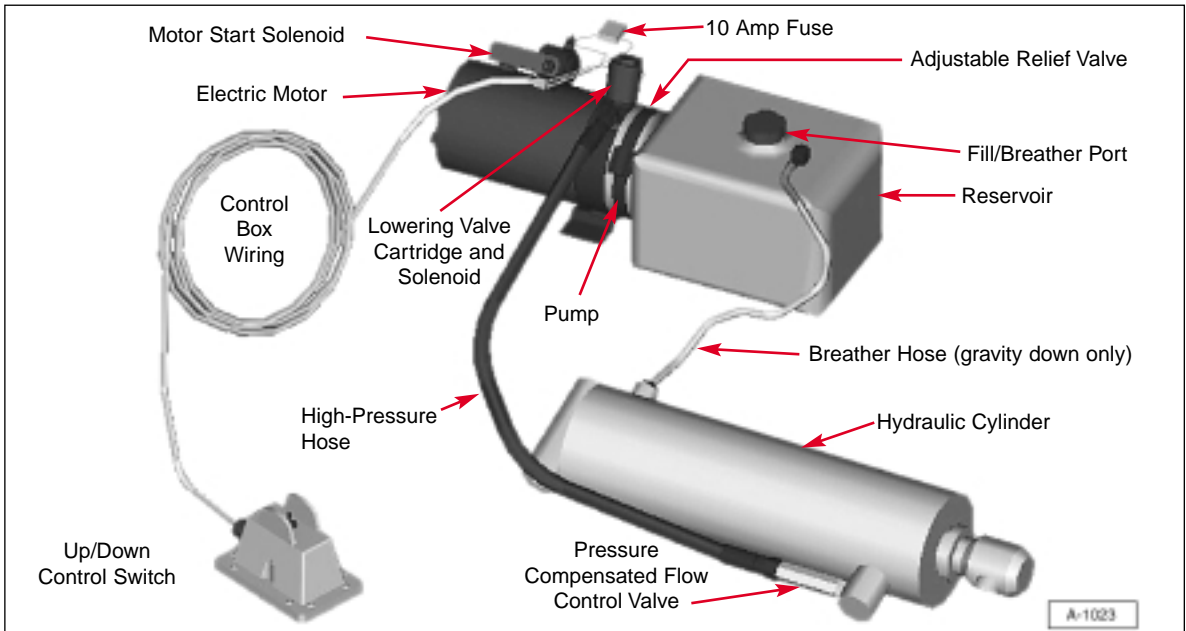

Power unit nomenclature.

General Information

Warranty

IMPORTANT NOTICE

The liftgate must be installed according to the installation instructions or the warranty will be void. Unauthorized modifications of the liftgate may cause it to improperly operate or cause other unforeseen problems or dangers. If any deviation is deemed necessary, written permission must first be obtained from Anthony Liftgates.

Fill out and mail in the Warranty Card to validate the warranty on your liftgate.

Decals



Safety decals provide a vital role in helping to reduce injuries and/or possibly even death. To ensure the greatest level of safety, all decals must be in place and legible at all times. Remember, it is the users responsibility to maintain these decals. For a complete part number list and illustration of the decals used on the Tuckunder liftgate, refer to the Decals section in the Parts manual for AST and ATU Model Tuckunder Liftgates, form number TU-P-08/00.

For decal placement, also refer to the Decals section in this manual.

For replacement decals contact:

Anthony Liftgates, Inc.
1037 West Howard Street
Pontiac, Illinois 61764
(815) 842-3383
www.anthonyliftgates.com

Ordering Parts

We manufacturer a quality liftgate that requires very little maintenance or repair. However, should a part break, become damaged, or worn our knowledgeable staff can make sure you receive the part(s) to put your liftgate back into operation.

For questions or to order parts, contact:

Anthony Liftgates, Inc.
1037 West Howard Street
Pontiac, Illinois 61764
(815) 842-3383
www.anthonyliftgates.com

Tooling Required

The following is a list of suggested tools that should be used to install the Tuckunder liftgate.

- Overhead Crane or Forklift
- Mig or Stick Welder
- Heavy-Duty C-Clamps
- Tape Measure
- Level (small, magnetic)
- Cutting Torch (in some applications)

Installation Section

General Installation Information

Fabricated Tooling

Tip: The lifting jig shown in the illustrations can reduce installation time when installing more than one Anthony Tuckunder liftgate. A forklift or overhead crane can also be used with a bolt and chain.



Sample lifting jig.

The photo shows a sample lifting jig. This lifting jig must be made specifically for the type and design of your particular forklift. Remember, the materials used to construct the lifting jig must be capable of lifting and supporting the Anthony liftgate being installed. The lifting jig must also contain a restraining method to hold the lifting jig in place on the forklift. The construction of this lifting jig must satisfy the user to be safe and properly constructed.



Lifting jig attached to liftgate. Lifting jig must support liftgate in a level position, as shown.

DANGER



The construction of the lifting jig must satisfy the user to be safe and properly constructed. Failure to use the proper materials or material thickness can result in serious injury or death to the user(s).

- Make the lifting jig from tubular steel at least 0.25 inches thick or thicker.
- Make the lifting bolt from a 5/8 inch threaded eyebolt. Use a washer and nut to fasten the lifting jig to the liftgate.
- Make the lifting jig wide enough to support the liftgate and to accommodate the width of the forks on the forklift.
- The lifting bolt should be long enough to go through the lifting hole in the liftgate and allow the lifting jig to remain level.

Prior To Installation

Tip: Check the OEM vehicle manual for any special requirements prior to welding on the truck. If required, disconnect the battery cable before welding on the truck.

If installing multiple liftgates, consider making a lifting jig as shown in the Fabricated Tooling section of this manual.

1. Place the truck on a flat, level surface. Block the wheels to prevent possible truck movement during liftgate installation.
2. Use the Mounting Requirements illustration and chart to make sure there is enough clearance to properly install the liftgate.

Mounting Requirements		
A Bed Height Floor Extension	B Bed to top of Tube Assembly	C Mounting Plate
36" - 41"	15-3/4"	29"
42" - 49"	19"	24-1/4"
50" - 51"	20"	23-3/4"
52" - 53"	21"	23-1/4"
54" - 55"	22"	22-5/8"
56" - 57"	23"	22-1/2"

⚠ **DANGER**



Failure to prevent the truck from moving during the installation of the liftgate could result in serious personal injury or crushing of the installer(s).

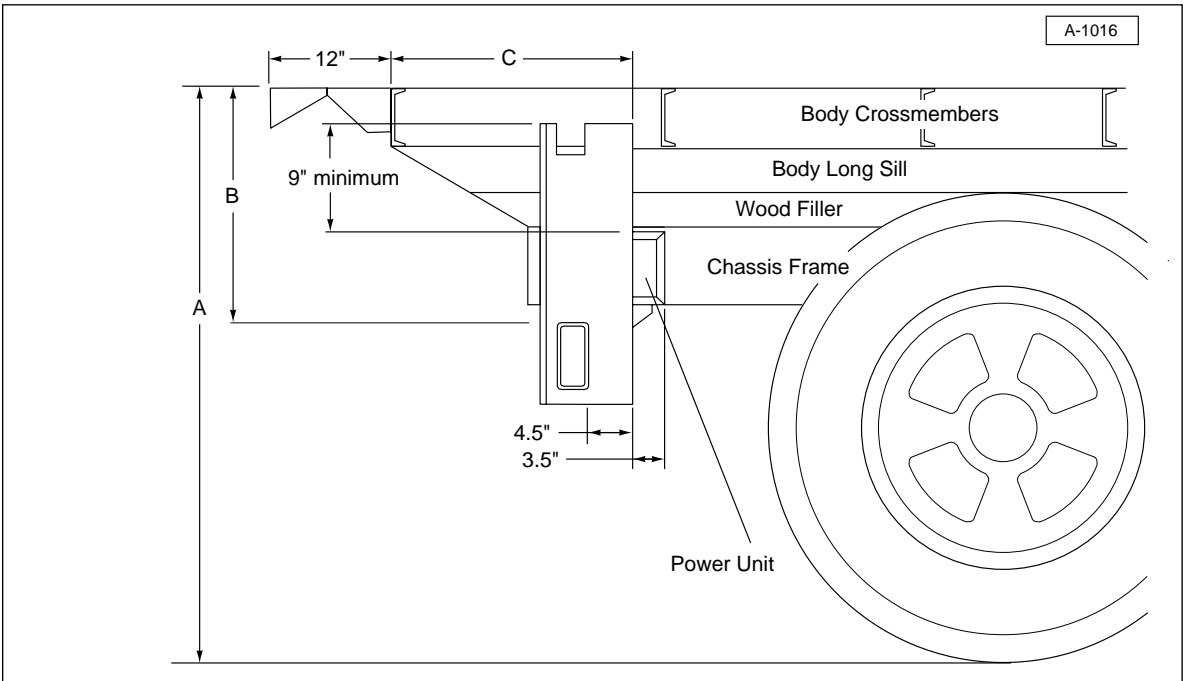

Mounting requirements. Refer to the Mounting Requirements chart for dimensions.

3. Remove the banding securing the liftgate and loose parts to the pallet. Remove the curbside and streetside mounting plates from the liftgate frame. Unfold the liftgate as shown.

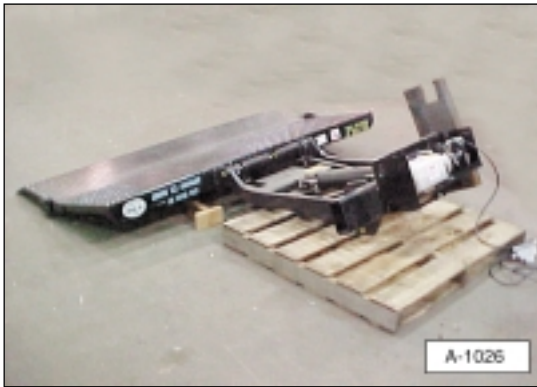

Unband and unfold the liftgate.

Installation Procedure

Step 1

Remove the cover from the power unit box. Remove all the parts and installation instructions from inside the box. Replace the plug in the power unit reservoir with supplied breather cap.

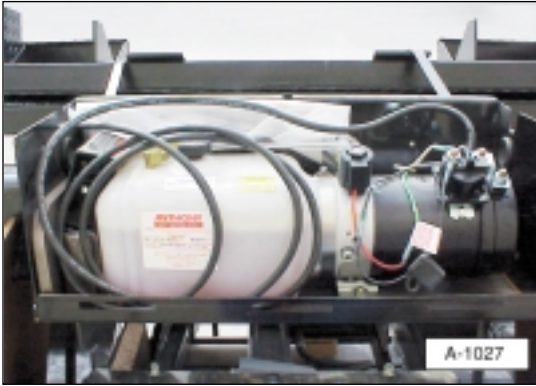

Illustration 1. Remove all loose parts and installation package.

Tip: The power unit box should contain plastic tie wraps for battery cable, two stop brackets, one latch plate, one 150 Amp circuit breaker, and one package containing decals, shims, and manuals.

Step 2

Cut off or extend the chassis frame, wood filler, and body long sill, as shown in Illustration 2. The frame must be flush to 12 inches forward of the rear of the truck body.

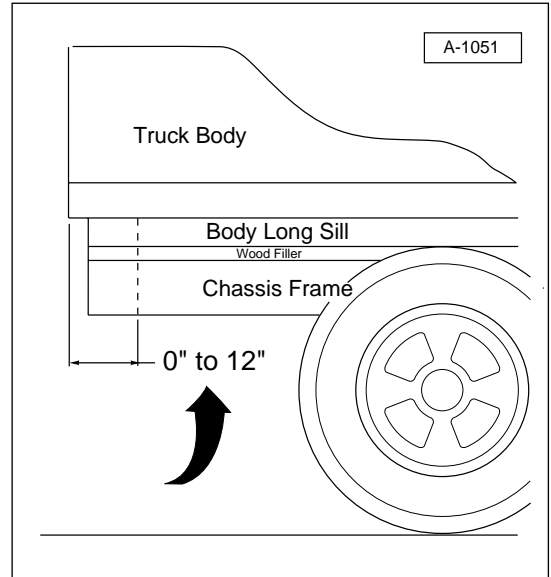

Illustration 2. Cut off or extend the body long sill and chassis frame to the dimensions shown in the illustration if the chassis frame is not within the 0 to 12" dimension shown above.

Tip: Before modifying the truck chassis, make sure the extensions meet the specifications of the truck manufacturer and that altering the frame will not void the truck warranty.

Step 3

Measure and determine the center of the truck's rear sill. Mark this point.



Illustration 3. Find and mark the center of truck's rear sill.

Tip: Two men are used in the welding process to reduce the time.

Step 4

Install the floor extension.

- a. Align the "Center Mark" of the floor extension assembly with the center of the truck body. Tack weld the assembly in three places (left, center, and right) level with the floor of the truck. The tack weld must hold the weight of the floor extension, approximately 200 pounds.



Illustration 4a. Align floor extension with mark.

CAUTION



Tack welds must be strong enough to hold the weight of the extension and the dock bumpers. Insufficient welds may not hold the truck extension in place, resulting in bodily harm.

- b. Make sure the floor extension is level and parallel to the truck's rear sill.



Illustration 4b. Level the floor extension.

- c. Tack the brackets under the floor extension to the truck body.



Illustration 4c. Tack weld floor extension brackets.

- d. Finish welding the floor extension to the truck body. Weld between the white dots painted on the floor extension (approximately 2 inches each).
- e. Weld the gussets under the floor extension to the truck body on both sides of the gusset.

Step 5

Lift and position the liftgate.

⚠ WARNING



Use extreme caution if working under the liftgate. Failure to safely secure the liftgate to the floor extension could cause serious personal injury. Do not remove the lifting device(s) until the liftgate is completely welded onto the truck.

- a. Attach a lifting device to the liftgate. A lifting jig is shown in the installation photos, however any lifting device capable of safely lifting and holding the liftgate can be used.



Illustration 5a. Use a forklift or overhead crane to lift the liftgate.

Tip: The lifting jig shown in Illustration 5a and 5b is not required for installation, but can reduce installation time when installing more than one liftgate. A forklift or overhead crane can also be used with a bolt and chain.

- b. Position the liftgate level with the floor extension and centered on the truck's rear sill. The outer edge of the liftgate should be 1/2 to 3/4 inches higher than the edge against the floor extension, as shown in Illustration 5c.



Illustration 5b. Align the center mark of the liftgate platform with the center mark on the floor extension.

- c. The position of the outer edge of the liftgate should be 1/2 to 3/4 inches higher than the edge against the floor extension, as shown in Illustration 5c.

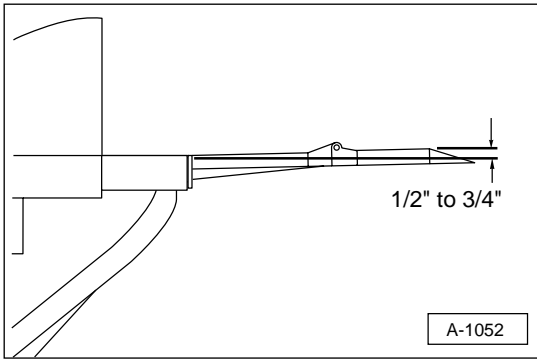

Illustration 5c. Raise the outer edge 1/2" to 3/4" above the edge against the floor extension.

Step 6

Clamp the liftgate onto the floor extension.

DANGER

To avoid personal injury, do not work under the liftgate or floor extension while installing or painting the liftgate. Work so that you would not be in the way if the clamps, weld, etc. should fail.

- a. Use two large C-clamps, as shown below, to hold the liftgate in place.

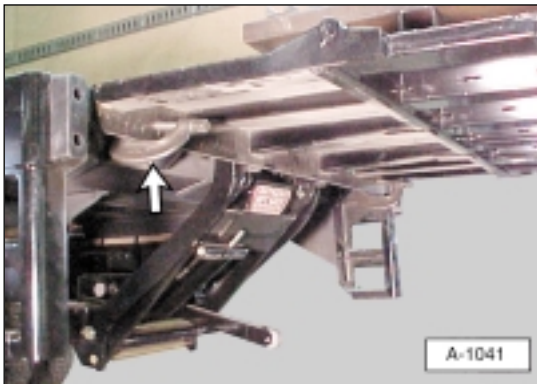

Illustration 6a. Clamp liftgate onto floor extension.

- b. An alternate method of holding the liftgate is using two, 3 to 4 foot long pieces of heavy-duty angle iron. The size of the angle iron should be 3 x 3 x 1/4 inch minimum.

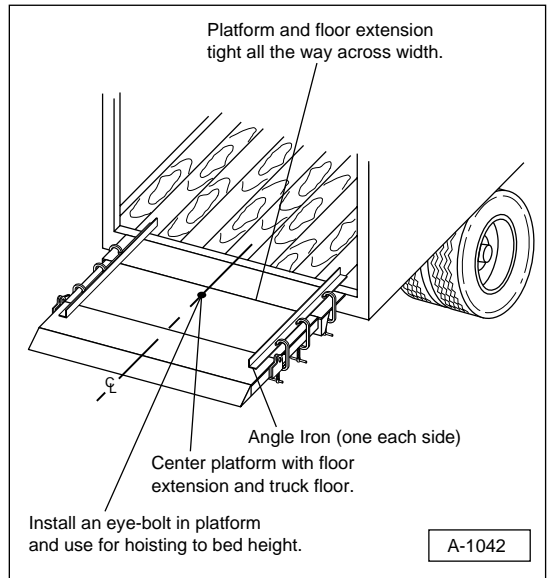

Illustration 6b. Use two pieces of angle iron clamped to liftgate to hold it in position.

Step 7

Install the circuit breaker. Make all electrical connections.

- a. Connect the end of the power cable to the motor solenoid on power unit.

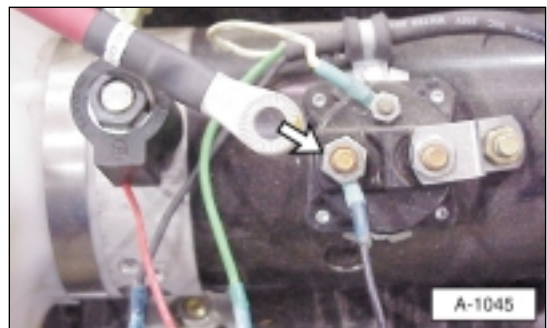

Illustration 7a. Connect power cable to motor solenoid lug.

⚠ DANGER



Never secure the power cable to anything which allows it to contact sharp edges, other wiring, fuel tank, fuel lines, brake lines, air lines, exhaust system, or any other object that could cause the power cable to wear or be damaged. A cut battery cable can cause sparks resulting in loss of vehicle control, serious injury, or even death.

- b. Route the power cable along the chassis frame rail to the truck's battery box. Secure the cable in place using the plastic tie wraps provided.
- c. Cut the power cable to the required length. Make sure it is long enough to connect to the 150 amp circuit breaker. Strip insulation one inch back from the end of the cable to expose the copper wire.

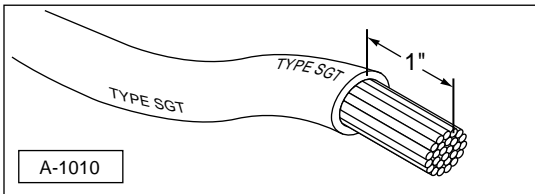

Illustration 7c. Remove one inch of insulation.

- d. Position the cable lug on the exposed wire, as shown. Crimp the cable lug using a cable crimping tool (hydraulic or manual).

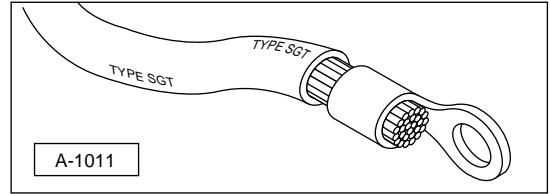

Illustration 7d. Install cable lug.

IMPORTANT NOTICE

Proper wire connections are crucial to the life of the liftgate's power unit. DO NOT smash the cable lug with a hammer to secure to the cable. Poor connections can result in low voltage, and any attempt to operate below the minimum required voltage could cause system failure.

- e. Use the supplied heat shrink tube to insulate the new connection. Heat the shrink tubing using a heat gun or propane torch until it shrinks around the cable insulation and cable lug, leaving only the mounting hole exposed. Do not overheat the heat shrink tubing.

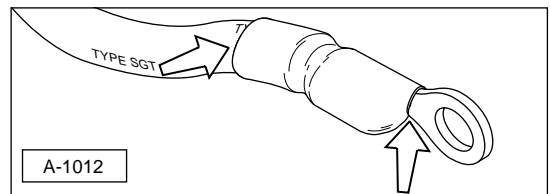

Illustration 7e. Put heat shrink tubing over connection.

IMPORTANT NOTICE

Make sure the heat shrink tube completely covers any bare wires. Exposed wire can arc when it comes into contact with a metal surface. This arcing can cause equipment damage and/or possibly start a fire.

- f. Install the 150 Amp Circuit Breaker somewhere near or in the battery compartment. Remove the black rubber cap from the terminal marked “AUX” on the circuit breaker and connect the power cable lug.

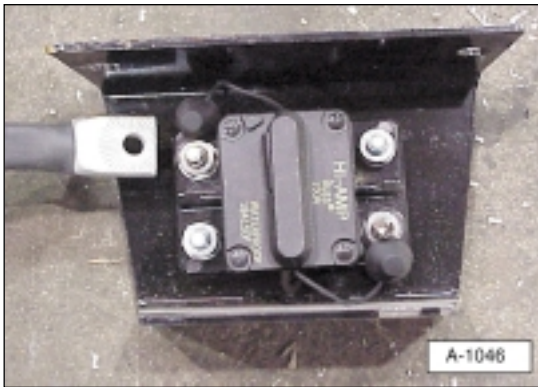

Illustration 7f. Install circuit breaker and attach power cable lug.

- g. Connect the power cable to the battery. Also install an optional power cut-off solenoid or cab cut-off switch at this time.

DANGER



Anthony Liftgates strongly recommends the installation of a power cut-off solenoid or cab cut-off switch. Allowing power to the liftgate when unattended can result in serious injury or death.

IMPORTANT NOTICE

If the battery is grounded to engine, make sure the engine is grounded to frame with same gauge wire as the power cable.

- h. For direct battery connection, remove the black rubber cap from the terminal marked “BAT” on the circuit breaker and connect a cable to the battery.

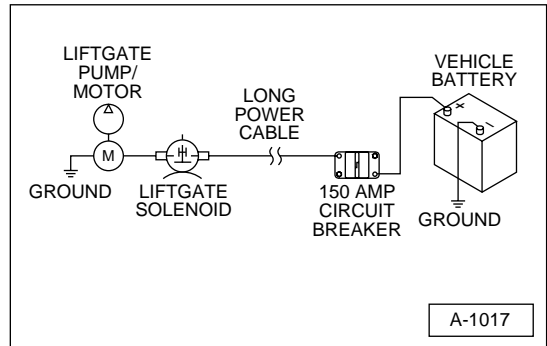

Illustration 7h. Power cable connected to circuit breaker and then to battery.

- i. For connection to a power cut-off solenoid, remove the black rubber cap from the terminal marked “BAT” on the circuit breaker and connect a cable to the optional power cut-off solenoid and then to the battery.

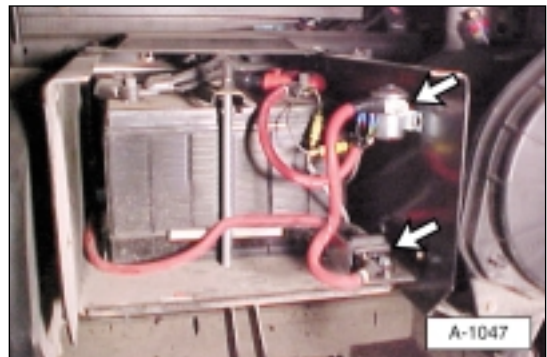

Illustration 7i. 150 Amp circuit breaker and optional power cut-off solenoid.

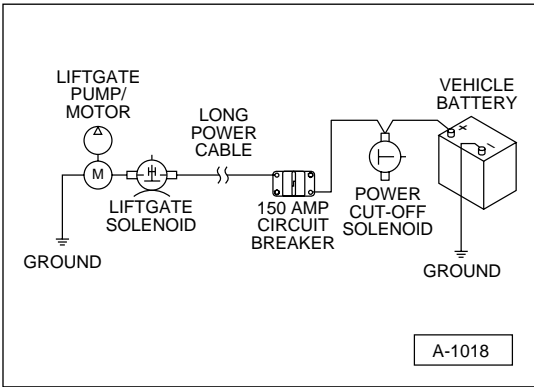

Illustration 7i Wiring diagram with circuit breaker and power cut-off solenoid.

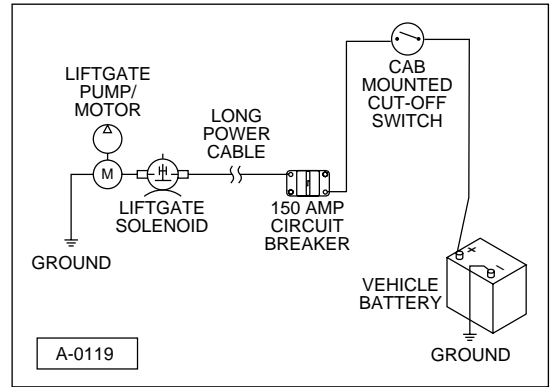

Illustration 7j. Wiring diagram with circuit breaker and cab cut-off switch.

- j. For connection to a cab cut-off switch, connect the optional cut-off switch as directed in the instructions accompanying the switch and as shown in Illustration 7j.

- k. After all the electrical connections to the power unit, circuit breaker, power cut-off solenoid, or cab cut-off switch are made, coat the terminal ends, studs, and nuts with a Teflon lubricant, grease, or other electrical connection sealant to prevent corrosion.



Illustration 7j. Cut-off switch mounted in cab of truck.

Step 8

Place a floor jack under the wheel arm, as shown in Illustration 8. Raise the wheel arm until the adapter frame is almost perpendicular to the truck frame, as shown in Illustration 9.



Illustration 8. Raise the tube assembly into place.

Tip: To ensure the lifting platform will remain level with the floor extension after normal wear, tilt the mounting plates and adapter frame tube slightly towards the cab of the truck until about 1/4 inch of the cylinder rod chrome is extended.

Step 9

Slide the mounting plates into position on the 3" x 6" adapter frame tube on each side and tack weld in place. Place tack welds at the locations marked "X" (each weld should be a 3/8 fillet, 1 inch long). The angle on the plate should face the rear of the truck, as shown.

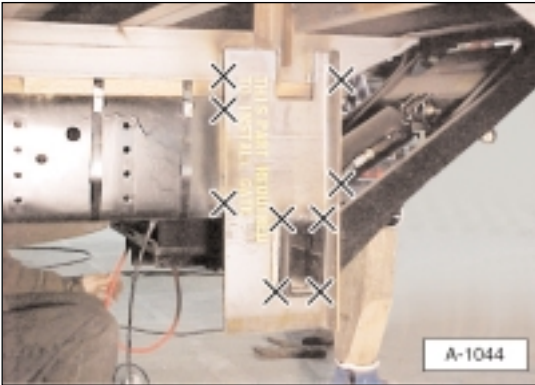

Illustration 9. Put mounting plates into position. Put 3/8 fillet by 1 inch long tack welds at locations marked "X".

Step 10

Remove the C-clamps, angle iron (if this method was used), lifting device, and jack.

Step 11

Standing on the curbside of the truck, away from the platform, actuate the DOWN button/switch to lower the platform to the ground and the UP button to raise the platform back to truck bed height. If the platform lowers to the ground and raises flush to the floor extension, finish welding the mounting plates. If the platform does not make a complete cycle, adjust the mounting plates, as necessary.

⚠ CAUTION



For safety purposes, weld the liftgate while the platform is on the floor, not in a raised position. Cover the cylinder rod to prevent weld spatter from damaging it.

Step 12

With the liftgate on the ground, completely weld the mounting brackets onto the chassis frame and tube assembly.

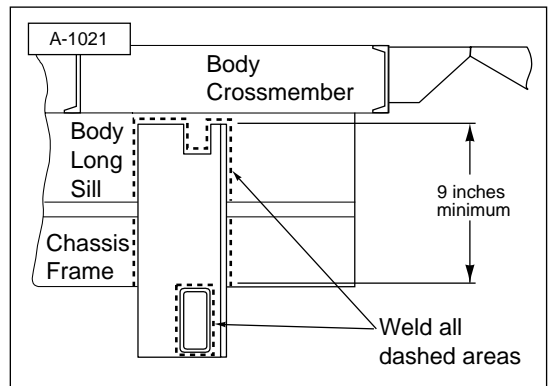

Illustration 12. Weld mounting plates to body long sill and chassis frame.

Step 13

Cut the chassis frame and body long sill as shown in Illustration 13. After making the cut out, make sure the liftgate operates properly without hitting the chassis frame or body long sill.

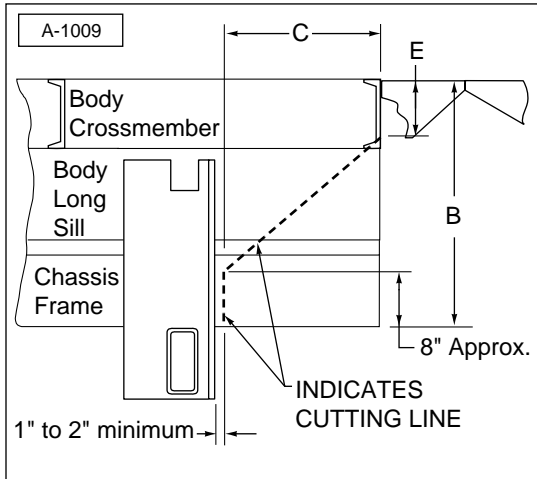

Illustration 13. Cut the body long sill and chassis frame.

Chassis Frame Length			
Bed Height Floor Extension	B	C	E
36" - 41"	15-3/4"	13-1/2"	3-3/4"
42" - 49"	19"	14-3/4"	4-1/4"
50" - 51"	20"	14-1/4"	5-1/8"
52" - 53"	21"	13-3/4"	5-3/4"
54" - 57"	22"	13-1/8"	6-1/4"

Step 14

Position the liftgate and weld the platform supports in place as follows:

- Fold the liftgate into the storage position. Using the up and down switch, position the liftgate until there is a 1/2" gap between the cylinder body and liftgate.

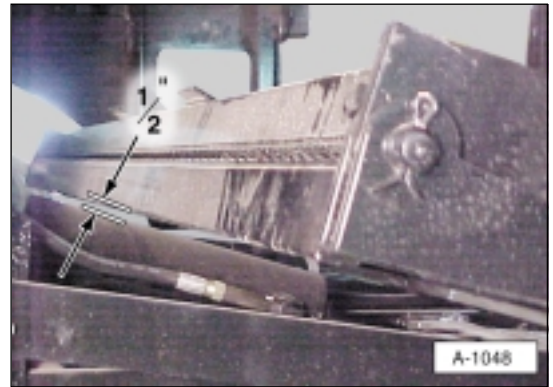

Illustration 14a. Adjust liftgate until there is a 1/2" gap between the cylinder and the liftgate.

- Position and tack weld the platform supports 1/16" to 1/8" from the platform on each side. If the liftgate operates properly, weld them in place on all three sides.

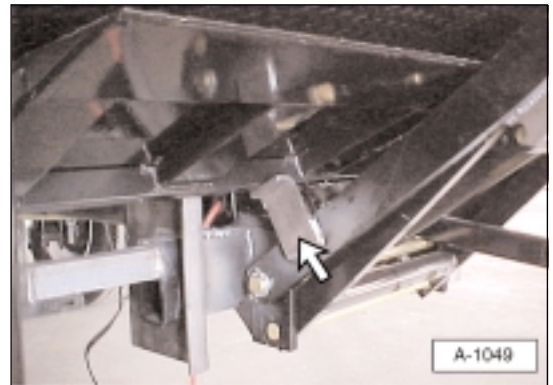

Illustration 14b. Weld platform supports into place on each side.

IMPORTANT NOTICE

The latch pin is only for in-transit locking of the liftgate. DO NOT slide the latch pin into the latched position when the platform is unfolded and raised. If this occurs, serious damage to the liftgate can occur when the liftgate is lowered.

Step 15

Attach the locking plate to the radius arm as follows:

- a. Raise the liftgate to the stored position and slide the latch pin across the radius arm.
- b. Position the locking plate on the streetside radius arm as shown. There should be a 1/16" gap between the radius on the locking plate and the latch pin.

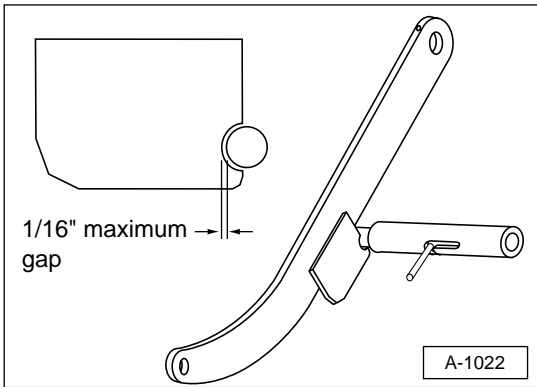

Illustration 15b. Position locking plate with 1/16" maximum gap.

- c. Weld the locking plate in two places with 3/8" fillet welds, as shown.

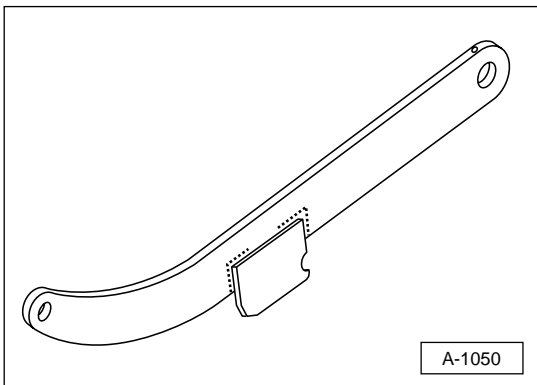

Illustration 15c. Weld locking plate to radius arm.

Step 16

Mount the control switch to truck's rear curbside post so it can be reached while standing at the curbside of the truck away and from the liftgate platform.

Tip: Mount the switch box before attaching the dock bumpers. This allows routing of the switch box wire through the slot in the dock bumper.



Illustration 16. Install the control switch.

Step 17

Weld both the streetside and curbside dock bumpers onto the floor extension.

- a. If necessary, route the control cable through the curbside dock bumper.

- b. Place the dock bumper corners in place and tack weld into position.



Illustration 17b. Tack weld dock bumpers.

- c. Weld the dock bumper corners continuously to the floor extension and the truck body.



Illustration 17c. Correctly welded floor extension and dock bumper corners.

Tip: Place a wet shop towel or rag around the switch box control cable when welding the curbside dock bumper to prevent burning or melting the control cable.

Step 18

Weld the side gussets to the dock bumper corners and the steel side member of the truck body or the cross-members of the truck body.

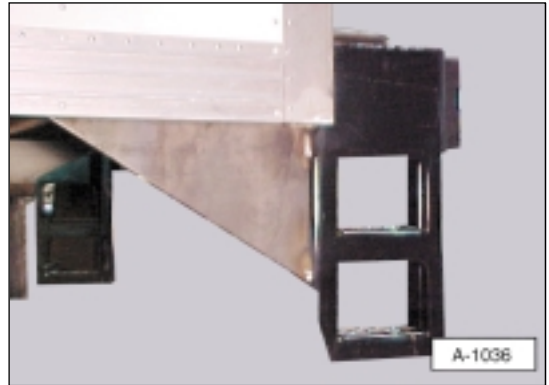

Illustration 18. Weld side gussets in place.

- a. The recommended method of attaching side gussets, is welding the gusset to the steel side member of the truck body.

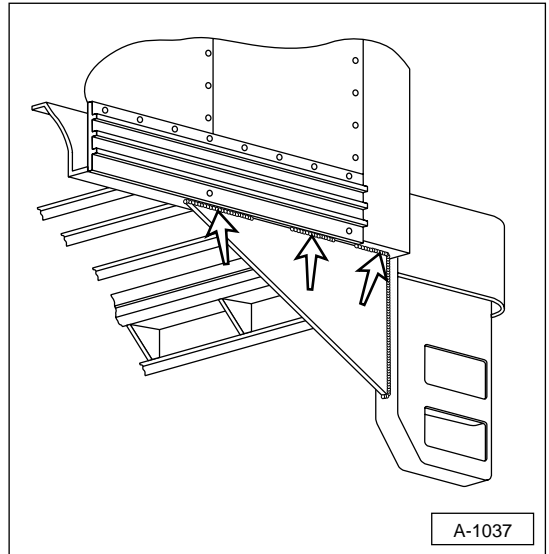

Illustration 18a. Side gusset welded to truck body.

- b. The alternate method of attaching the side gussets is to weld the gusset to the steel cross-members of truck body. Make sure gusset straddles at least three cross members. Weld both sides of each gusset.

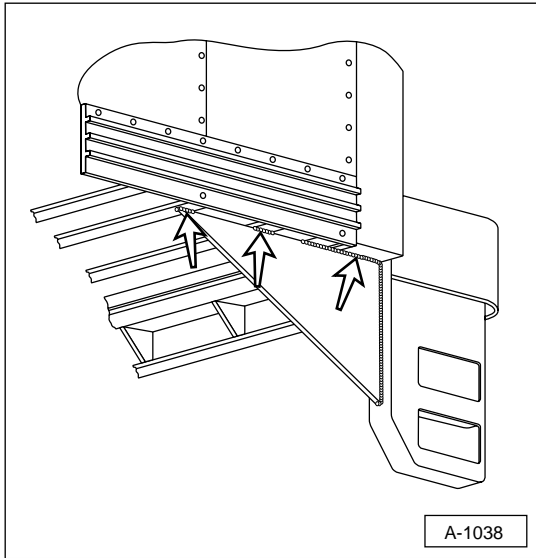

Illustration 18b. Side gusset welded to cross-members.

Step 19

Install lights or other electrical components, if needed.

Step 20

Install grab bars or hand rails, as may be necessary. Also, install license plate holder, as necessary.

IMPORTANT NOTICE

Some models of Anthony liftgates may be provided with step devices to assist in the ingress or egress of the rear of the truck or trailer. These devices are NOT to be considered all inclusive of any requirements or guidelines regarding proper ingress or egress of trucks and trailers. These items are provided only as an added feature for installers to help simplify the meeting of possible ingress or egress requirements. As there are many variables in truck sizes and shapes, it is the installers responsibility to determine proper ingress and egress requirements, such as steps, hand grips, grab bars, etc. for each vehicle receiving an Anthony liftgate.

Step 21

Make a final operation check.

- a. Make sure the platform will travel through a complete cycle, up and down, smoothly and freely, with the platform completely open.
- b. Make sure the platform will fold and tuck under the truck in a stored position, and latch. The liftgate must fold smoothly and freely.
- c. Make sure hydraulic hose fittings are tight and hydraulic hose does not rub against the liftgate or other parts while cycling up, down, open, and closed. Adjust as necessary by loosening fittings and adjusting the position of the hose(s). Retighten fittings.

Step 22

Attach all decals, as shown in the Decal section of this manual.

Step 23

Complete the Final Checklist section.

Final Inspection Checklist

DANGER



Do not use the liftgate if any of the items in the Final Checklist are not checked and verified. If you have any questions, contact your nearest Anthony distributor, or the Anthony Liftgates main office.

- Check all welds to make sure they are done properly.
- Make sure all pins are in place and held with proper retainers.
- Make sure the power unit reservoir is filled.



Fill hydraulic tank to within 1/2 inch from the top of the tank.

For **Gravity Down** models: the fluid level should be 1/2" from the top of the reservoir when the liftgate platform is on the ground.

For **Power Down** models: the fluid level should be 1/2" from the top of the reservoir when the liftgate platform is in the fully raised position.

- Install cover on power unit box. Make sure it is secured with a padlock, lock pin, or wire (customer supplied).
- Operate the liftgate through its entire operational cycle (Up, Down, Open, Close) several times. Make sure the liftgate operates evenly, freely, and smoothly throughout the entire operating range and that there is no unusual noise or vibration while operating the liftgate.
- Make sure the platform is adjusted properly (1/2 to 3/4 inch rise) with the necessary shims.
- Make sure all decals are in place and legible.
- Make sure license plate bracket is properly installed, as required by law.
- Make sure lights are installed and operating properly, per FMVS 108.
- Make sure reflectors are re-installed, if any.
- Make sure grab handles and other ingress/egress items are properly installed as may be necessary.
- If rubber dock bumper pads are required, bolt them in place to dock bumper corner caps.
- Make sure the optional cab cut-off switch or power cut-off solenoid is installed.
- Put Installation, Operation, and Maintenance manual and Parts manual in the vehicle.

Decals

⚠ DANGER

Make sure all decals are attached to the liftgate and/or truck and are legible at all times.

Safety decals provide a vital role in helping to reduce injuries and/or possibly even death. To ensure the greatest level of safety, all decals must be in place and legible at all times. Remember, it is the users responsibility to maintain these decals. For a complete part number list of the decals used on the Tuckunder liftgates, refer to the Decals section in the Parts manual for AST and ATU Model Tuckunder Liftgates, form number TU-P-08/00.

For replacement decals contact:
Anthony Liftgates, Inc.
1037 West Howard Street
Pontiac, Illinois 61764
(815) 842-3383
www.anthonyliftgates.com

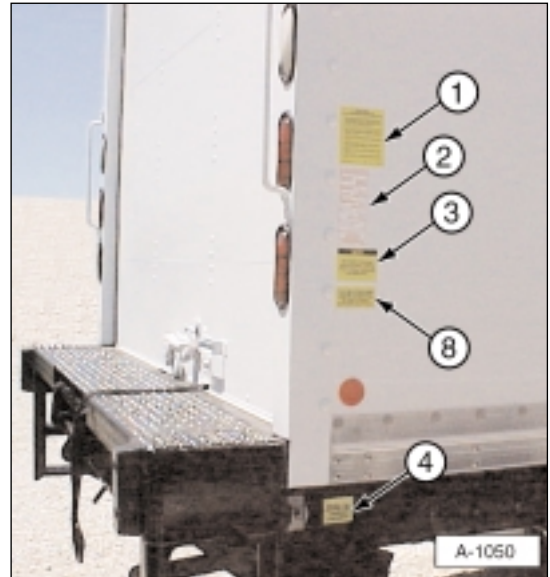

1.

URGENT WARNING
ELEVATING GATE INSTRUCTIONS

Before Operating Lift, Be Sure You Understand the Following.

1. Improper operation of this lift can result in serious personal injury. Do not operate unless you have been properly instructed and have read and are familiar with, the operating instructions. If you do not have a copy of the instructions please obtain them from your employer, distributor, or lessor, as appropriate, before you attempt to operate the lift.
2. Be certain the vehicle is properly and securely braked before using the lift.
3. Always inspect this lift for maintenance or damage before using it. If there are signs of improper maintenance, damage to vital parts, or slippery platform surface, do not use the lift. Do not attempt your own repairs, unless you are specifically trained.
4. Do not overload. See Mfg. Literature and/or Rating Label on the unit for the rated load. Remember that this limit applies to both raising and lowering operations.
5. Each load should be placed in a stable position within the edges of the platform as near as possible to the center of the platform side to side, and as close to the truck sill as possible.
6. Never stand in or move through or allow anyone else to stand in or move through the area in which the lift may operate or into which an upset load might fall.
7. This is not a passenger lift. This liftgate is intended for loading and unloading of cargo only. Do not use this liftgate for anything but its intended use.

Anthony Liftgates, Inc.

6/95

Q-003013

2.

ANTHONY ATU, AST, AK & LB LIFTGATE OPERATING INSTRUCTIONS

1

UNLATCH LIFTGATE BY
TWISTING, THEN SLIDING
“LATCH PIN” IN
DIRECTION OF ARROW

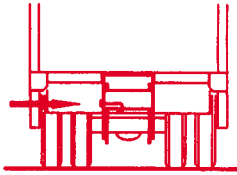

2

LOWER PLATFORM
BY PUSHING CONTROL
SWITCH TO “DOWN”
POSITION

Platform will begin
to open as it lowers.

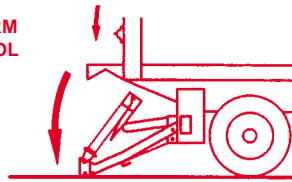

3

UNFOLD PLATFORM BY
PULLING PLATFORM HANDLE
OUTWARD AND TOWARD
GROUND.

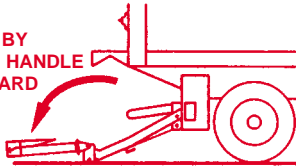

4

UNFOLD FLIP SECTION.

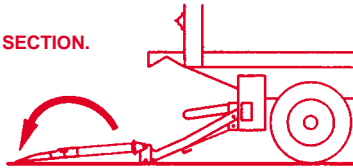

5

FLIP SWITCH “UP” TO RAISE PLATFORM
-OR-
FLIP SWITCH “DOWN” TO LOWER PLATFORM



6

TO TUCK UNIT UNDER AFTER USE, LOWER PLATFORM
TO GROUND AND REVERSE STEPS



ANTHONY LIFTGATES, INC.

1037 WEST HOWARD ST., PONTIAC, IL 61764

ATU-423

3.

NOTICE

**THIS LIFTGATE IS PROTECTED WITH
AN ELECTRICAL OVERLOAD
CIRCUIT BREAKER, LOCATED NEAR
THE POWER SUPPLY.**

A-150238

4.

**1500 lb.
MAXIMUM
CAPACITY**

A-131015

IMPORTANT NOTICE

Make sure the proper "maximum capacity" decal goes on the appropriate liftgate. For example, the "1500 maximum capacity" decal goes on AST1500 models only. Do not put a higher rated decal (3000 pound) on a smaller liftgate (model 1500); this could result in liftgate damage or possibly personal injury.

5.

STAND CLEAR

**DO NOT RIDE
ON LIFT**

ATU-146

6.

**SECURE LATCH WHILE
IN TRANSIT**



P/N ATU-143

7.

Note:

**Disengage “latch”
before attempting to
use liftgate.**

**Engage “latch” after
using liftgate.**

A-131017

8.

**AFTER USING LIFTGATE, SECURE
LATCH AND, IF EQUIPPED WITH
POWER CUT-OFF SWITCH, TURN
OFF POWER TO PREVENT
UNAUTHORIZED USE OF LIFTGATE**

ATU-141

Operation Section

General Safety Operating Instructions

⚠ DANGER



Do not stand in the platform's work area while operating the liftgate. Serious injury or death could result if the load shifts or is unstable on the platform.

The following is a list of Do's and Don'ts for the operation of the liftgate.

✓ Do's

- ✓ Read and follow warning decals, operating decals, and owners manual.
 - ✓ Keep all decals in place and legible and retain the owners manual in the vehicle or all Warranties are void.
 - ✓ Make sure the vehicle is properly and securely braked before using the liftgate.
 - ✓ Keep yourself clear of all moving parts.
 - ✓ Make sure the area in which the platform will open and close is clear before opening, closing, raising, or lowering the platform.
 - ✓ Make sure the platform area, including the area in which loads may fall from the platform, is clear before, during, and at all times while operating the liftgate.
 - ✓ Always place the load as close to the center of the platform as possible. Also, position the load as close to the center of the truck's rear sill as possible.
- ✓ Only operate the liftgate with the push button/switch controls mounted on the truck body.
 - ✓ Check the oil level in the hydraulic monthly. Change it if it is contaminated or dirty.
 - ✓ Visually inspect your liftgate frequently and keep it properly adjusted.
 - ✓ Repair any damage to the liftgate to prevent accidents.
 - ✓ Lock the liftgate into the storage position with the latch pin when the liftgate is not in use.



Proper operating position.

X Don'ts



- X Do not overload the platform. The maximum rated capacity is based on an evenly distributed load on the platform's flat surface.
- X Do not ride on the liftgate. Always stand clear of liftgate when it is operating.
- X Do not allow children to play around or operate the liftgate.
- X Do not allow your liftgate to be used by persons not familiar with its operation.
- X Do not use your liftgate if it shows signs of abuse or fails to operate freely.
- X Do not allow the motor/pump to run after the liftgate is closed, or in the up position.
- X Do not use brake fluid in the hydraulic reservoir.
- X Do not bounce the platform by pushing and releasing the control button/switch abruptly.
- X Do not use the liftgate for anything other than its intended use of loading and unloading cargo.
- X Do not operate lift trucks on or over any part of the platform.
- X Do not stand under or place any object under the liftgate work area.

Operating Instructions

Opening and Closing the Liftgate

Step 1

Twist and slide the latch pin toward curbside of the liftgate.

Step 2

Stand clear of the platform and lower the liftgate by pressing "Down" on control button/switch.

Step 3

Open the platform.

Step 4

Open the flipover ramp.

Step 5

Press the "Up" switch to raise platform or the "Down" switch to lower the platform.

Step 6

To tuck the liftgate into its storage position after use, reverse Steps 1, 2, 3, and 4 from ground level.

ANTHONY ATU, AST, AK & LB LIFTGATE OPERATING INSTRUCTIONS

1

UNLATCH LIFTGATE BY
TWISTING, THEN SLIDING
"LATCH PIN" IN
DIRECTION OF ARROW

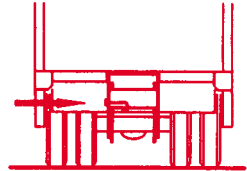

2

LOWER PLATFORM
BY PUSHING CONTROL
SWITCH TO "DOWN"
POSITION

Platform will begin
to open as it lowers.

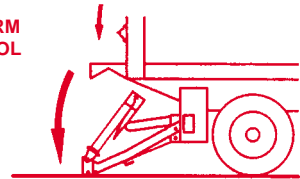

3

UNFOLD PLATFORM BY
PULLING PLATFORM HANDLE
OUTWARD AND TOWARD
GROUND.

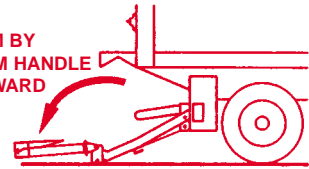

4

UNFOLD FLIP SECTION.

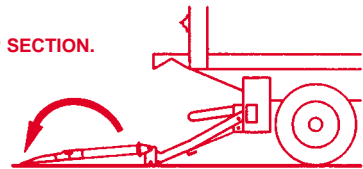

5

FLIP SWITCH "UP" TO RAISE PLATFORM
-OR-
FLIP SWITCH "DOWN" TO LOWER PLATFORM



6

TO TUCK UNIT UNDER AFTER USE, LOWER PLATFORM
TO GROUND AND REVERSE STEPS



ANTHONY LIFTGATES, INC.

1037 WEST HOWARD ST., PONTIAC, IL 61764

ATU-423

Maintenance Section

Quick Check Maintenance Guide

Monthly Inspection

SPECIAL NOTE: As of December 1994 Anthony Tuckunder Liftgates are “Service-Free”. This means that newer liftgates have lubrication-free bushings at the major pivot points which, of course, do not require lubrication. Consequently these liftgates do not have grease zerks. Models manufactured previous to December 1994, with grease jerks, require routine lubrication at major pivot points.

1. Make sure the liftgate operates freely and smoothly throughout its entire range of movement.
2. Check for damage to the liftgate such as bent or distorted members, or any cracked weld which may have resulted from overload or abuse. Check for excessively worn parts. Replace bushings and pins if extremely worn.
3. Check all pins and pivot points. Make sure they are secured with proper retainers.
4. Make sure platform is angled upward from truck bed 1/2 to 3/4 inch when raised to bed height. See Platform Adjustment for a shimming procedure.
5. Make sure all electrical wires, switches, and connections are in good working condition and operate properly.
6. Check for oil leaks in these areas:
 - a. Hydraulic lift cylinder.
 - b. Hydraulic hoses. Replace if they show signs of leakage or excessive abrasion of the covering.
 - c. Check all hydraulic fittings for damage or leaks. Tighten fittings to stop leaks or replace if damaged.
7. Check reservoir oil level.
 - a. Gravity down models - With the platform on the ground, the oil level should be within 1/2 inch of the top of the reservoir.
 - b. Power down models - Place liftgate in the fully raised, the oil level should be within 1/2 inch of the top of the reservoir.
 - c. Fill as required with Penzoil AWX Automatic Transmission Fluid or equivalent.

IMPORTANT NOTICE

Use only Penzoil AWX Automatic Transmission Fluid or equivalent in the power unit reservoir. Do not use brake fluid.

8. Check the fluid level of the vehicle battery. Fill as required.
9. Examine all Warning, Capacity, and Operational Decals. If they are not readable they should be replaced. Decals may be obtained free of charge from Anthony Liftgates, Inc.
10. Oil the roller wheel and make sure it spins freely.

Maintenance and Troubleshooting Procedures

Platform Adjustment (adding shims)

The ramp (outboard) end of platform should be 1/2 to 3/4 inches higher than truck floor. If the outboard end of the platform is sagging, add shims as described below to raise the end. Shimming is a normal procedure as the liftgate ages and the parts become worn.

1. Position the necessary amount of "shim plates" in the contact area between the cam plates and platform.

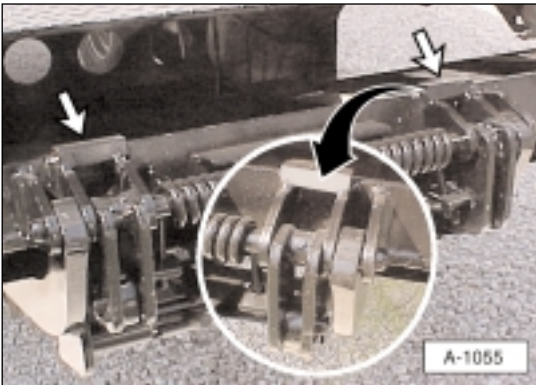

Add shims to this area to eliminate sagging.

2. Weld the steel shim plates to the blocks on platform.
3. When the platform is lowered to the ground, it should touch at the lift arm end and at the ramp end.

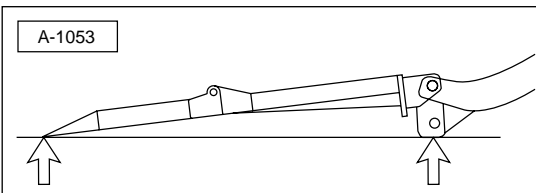

Liftgate should contact the ground at these two locations.

Checking the Control Switch

The control switch can easily be checked to make sure it is operating properly.

⚠ CAUTION

Stand clear of the liftgate when checking the control switch. It is possible for the liftgate to activate when testing the switch, which could lead to personal injury.

Gravity Down Models

1. Connect one end of a continuity tester to either top terminal (3) or bottom terminal (2).

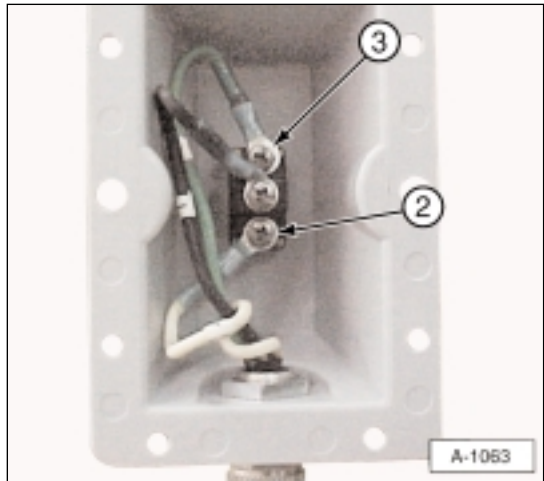

Inside of gravity down control switch.

2. Connect the other end of the continuity tester to a chassis ground or the body ground.

3. Once connected, flip the switch for that function (up or down). If the switch is good, the tester will light to indicate good continuity. If the tester does not light, then that function of the switch is bad.
4. Repeat the procedure for the other terminal.
5. If the switch is bad, replace it.

Power Down Models

1. Connect one end of a continuity tester to terminal [2 (a or b), 3, or 4).

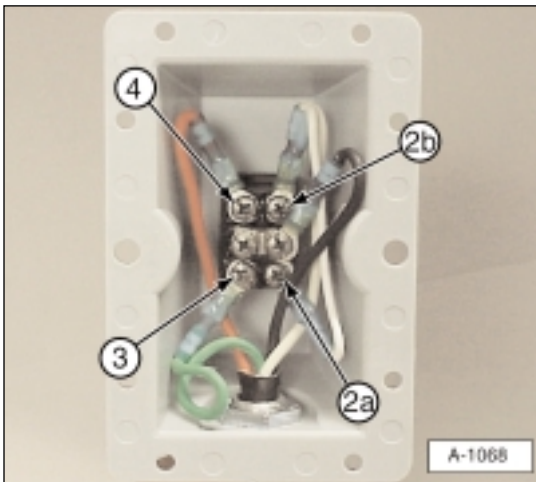

Inside of power down control switch.

2. Connect the other end of the continuity tester to a chassis ground or the body ground.
3. Once connected, flip the switch for that function (up or down). If the switch is good, the tester will light to indicate good continuity. If the tester does not light, then that function of the switch is bad.
4. Repeat the procedure for the other two terminals.
5. If the switch is bad, replace it.

Checking Motor Start Solenoid and Power Cut-off Solenoid

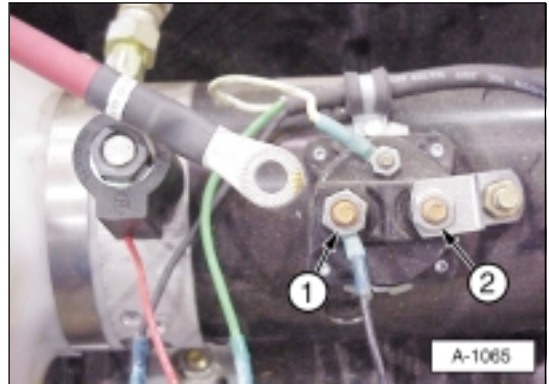

Motor start solenoid.

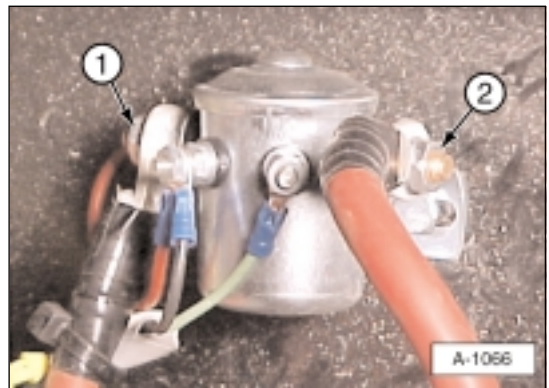

Power cut-off solenoid.

Both the motor start solenoid and power cut-off solenoid can be checked by bypassing the solenoid itself.

1. Use jumper cables for this test.
2. Connect one jumper cable to the battery side (2) of the solenoid. Connect the other cable to the motor side (1) of the solenoid.
3. If the liftgate is activated, the solenoid is bad and should be replaced.

Checking Battery Cable

To check for a bad battery cable, run the motor directly from a spare battery using jumper cables.

1. Remove the battery connection to the motor.
2. Connect the negative jumper cable (ground) directly to the liftgate. Connect the positive cable to the terminal on the motor start solenoid.
3. If the motor operates, the battery cable is bad and should be replaced.

Checking Lowering Valve Cartridge and Solenoid

1. Place liftgate on the ground in the open position.
2. Place a steel screwdriver over the top of the lowering valve solenoid.

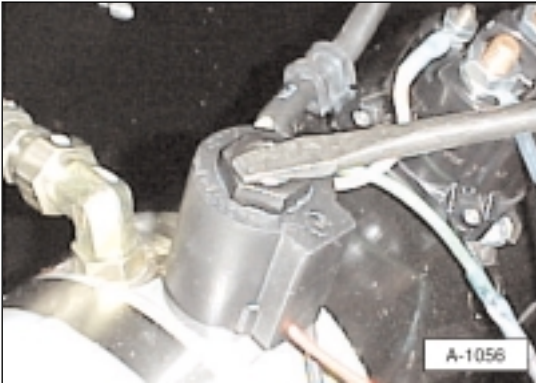

Place a screwdriver over the solenoid.

3. Momentarily activate the control switch in the DOWN position. The screwdriver should be attracted to the magnetic field created by the solenoid.

4. If no magnetic pull is produced, the solenoid is bad and should be replaced. If the solenoid is good, check the cartridge valve.
5. Remove the solenoid from the valve assembly.
6. Remove the valve cartridge from the pump body.
7. Clean the cartridge and blow it dry with compressed air (not greater than 30 psi). Also blow out the pump body.
8. Use a small screwdriver and carefully press on the spool inside the cartridge. If the spool moves freely, the cartridge is good. If it does not move, replace the cartridge, because the spool could be bent, pitted, or damaged in some other way.

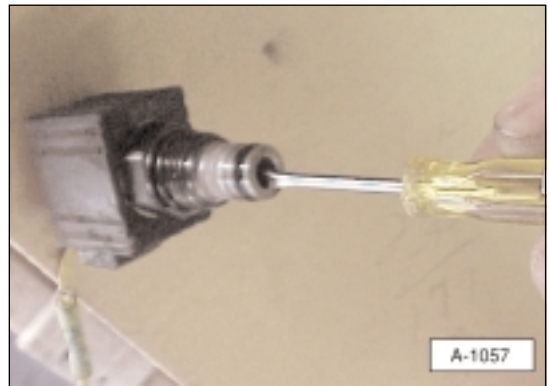

Push spool to check for free movement.

Checking Cylinder Piston Seals (drifting - caused by seal leakage)

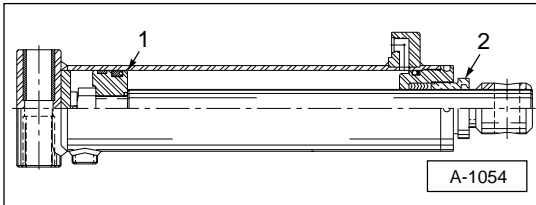

Piston rod and seals (1) and packing gland nut and seals (2).

Piston Rod Seals (Gravity Down)

1. Remove the breather hose (gravity down models only).
2. Raise the liftgate all the way up and hold the switch in the “on” position while checking for oil coming out of the cylinder’s breather port.
3. If a continuous flow of oil comes out of this port (while the liftgate is all the way up and the switch is held “on”), then the piston seals are leaking and the cylinder should be rebuilt or replaced.

If the cylinder is under warranty, do not rebuild. In these cases the cylinder will be replaced.

Piston Rod Seals (Power Down)

1. Check the lowering valve. Make sure it is operating correctly and the valve is not sticking or dirty.
2. If the lowering valve is operating properly, then the drifting is most likely caused by worn piston seals. Rebuild the cylinder and replace the piston seals.

If the cylinder is under warranty, do not rebuild. In these cases the cylinder will be replaced.

Packing Gland Nut

If the packing gland seals are leaking, oil will flow out of the gland nut and down the cylinder. This leakage can be stopped in most cases by tightening the gland nut.

1. Place the platform on the ground.
2. Use a pipe wrench or other suitable wrench to tighten the gland nut 1/4 to 1/2 of a turn. Do not tighten the nut more than 1/2 turn at a time.

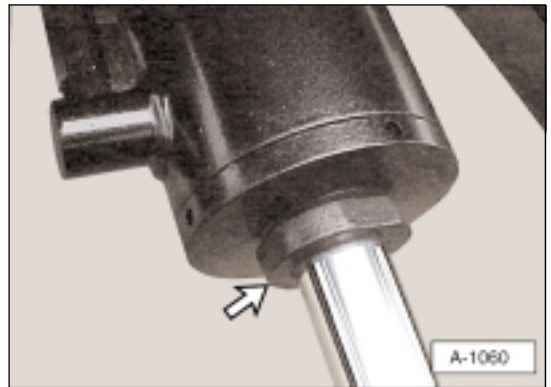

Packing gland nut.

3. If the packing gland nut continues to leak, tighten the nut again or rebuild the cylinder using a new seal kit.

IMPORTANT NOTICE

Do not overtighten the packing gland nut. If the cylinder does not extend or extends very slowly, the packing gland nut may be too tight. If the leak cannot be stopped by tightening the packing gland nut, rebuild the cylinder and replace the packing gland seal.

Checking and Adjusting System Pressure

For gravity down systems there is only one relief valve (power up) for setting pressure. Power down models have two relief valve settings; one for raising the platform (power up) and one for lowering the platform (power down).

To check the “power up” pressure setting:

1. Place the liftgate on the ground and remove the pressure hose from the power up port of the pump.
2. Install a tee (customer supplied) into the power up port.
3. Connect a pressure gauge and reconnect the hydraulic hose.

The pressure gauge must be rated above the maximum pressure of the liftgate. For example, use a 4000 psi pressure gauge on a 3000 psi maximum capacity liftgate.

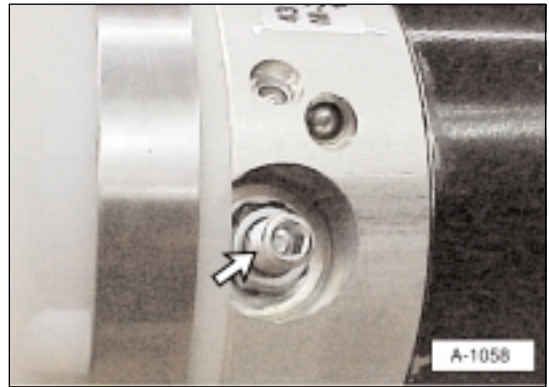

Relief valve adjustment for gravity down systems.

5. With the liftgate on the ground, loosen the locknut. Use an Allen wrench and turn the pressure adjustment screw counterclockwise to increase pressure and clockwise to decrease the pressure.

If the appropriate pressure cannot be reached, replace the pump.

6. Hold the valve adjustment screw in place and tighten the locknut. This method will prevent the adjustment screw from turning when the locknut is tightened.

⚠ DANGER



Do not stand or work in the platform's work area while operating the liftgate. Place the pressure gauge so it can be read while operating the liftgate from a safe location. Serious injury or death could result if this action is not followed.

4. Raise the liftgate and check the pressure. If the pressure is low, adjust the pressure relief valve.

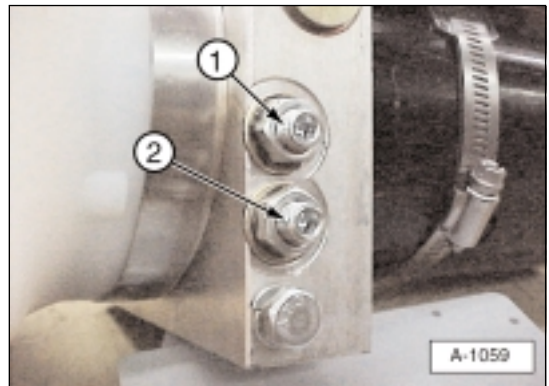

Relief valve adjustment for power down systems. (1) Power-up adjustment. (2) Power-down adjustment.

7. Check the power down relief valve pressure in the same way as the gravity down system by installing a tee and gauge.
8. The power down pressure should not exceed 400 psi. Turn the adjusting screw counterclockwise to decrease the pressure and clockwise to increase the pressure.

Flow Control Valve

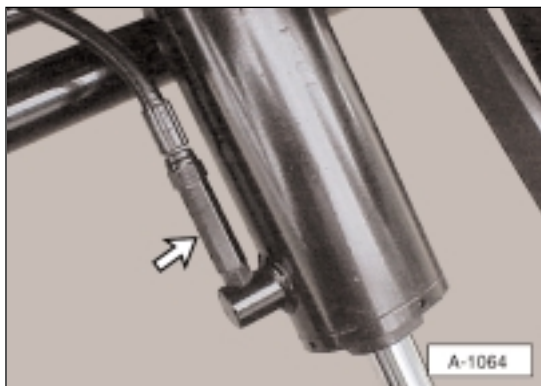

Flow control valve.

If the cylinder does not operate or operates slower than normal, remove the flow control valve and hook the hydraulic hose directly to the cylinder. If the cylinder operates properly, replace the valve.

⚠ DANGER	
	Do not operate the liftgate without the flow control valve. Serious injury or death could result if this action is not followed.

Safety Section

Safety

Safety is Your Responsibility

It is the responsibility of the installer/operator to understand and perform proper operating procedures. Be aware of the inherent dangers in the use of this product and the tools used to install it. Read and understand all Danger, Warnings, Cautions, and Important Notices in this manual and on the liftgate or truck.

Safety Signal Words

A signal word or words call attention to the safety sign and designate a degree or level of hazard seriousness. The signal words for Anthony Liftgates' product safety signs are DANGER, WARNING, CAUTION, and IMPORTANT NOTICE.

DANGER

DANGER: Indicates an imminently hazardous situation which, if not avoided, will result in death or serious injury. This signal word is limited to the most extreme situations.

WARNING

WARNING: Indicates a potentially hazardous situation which, if not avoided, could result in death or serious injury.

CAUTION

CAUTION: Indicates a potentially hazardous situation which, if not avoided, may result in minor or moderate injury. It may also be used to alert against unsafe practices.

IMPORTANT NOTICE

Indicates that equipment or property damage can result if instructions are not followed.

Safety Rules

DANGER



To avoid personal injury or death, carefully read and understand all instructions pertaining to the Anthony Liftgates product. Do not attempt to install, operate, or maintain our product without fully understanding all our instructions and safety precautions. Do not operate or work on a truck or liftgate unless you read and understand the instructions and warnings in the Installation, Operation, and Maintenance manual. If any doubt or question arises about the correct or safe method of performing anything found in this or other Anthony Liftgates' manuals, contact your Anthony Liftgates' dealer or call the Inside Sales and Service representatives at our main headquarters. Proper care is your responsibility.

DANGER



To prevent injury, the liftgate should only be installed by a qualified installer having knowledge and skill in using welding equipment and a cutting torch.



Always weld in a well ventilated area and, if in an enclosed area, vent the fumes to the outside. Breathing welding smoke and paint fumes can cause serious injury.



Always follow all State and Federal health and safety laws and/or local regulations when using an arc welder, mig welder, or cutting torch. Also, follow all manufacturer's safety guidelines. If other people are present during the installation of the liftgate, make sure the welding area is shield from their view. This will help prevent serious eye injury from the bright light.



To avoid eye injury during welding, always wear a welding helmet with the proper lens to shield your eyes from the bright light.



Failure to prevent the truck from moving during the installation of the liftgate could result in serious personal injury or crushing of the installer(s).

DANGER



To prevent injury, make sure all decals are attached to the liftgate and/or truck and are legible at all times.

DANGER



To prevent serious bodily injury, keep sparks, lighted matches, and open flames away from the top of the battery, because battery gas can explode. Always follow all the manufacturers' safety recommendations when working around the truck's battery.



Take precautions to avoid sparks coming into contact with the truck's fuel tank, brake lines, or other flammable components. Sparks can cause an explosion of combustible materials, resulting in serious injury or death.



Never secure the power cable to anything which allows it to contact sharp edges, other wiring, fuel tank, fuel lines, brake lines, air lines, exhaust system, or any other object that could cause the power cable to wear or be damaged. A cut battery cable can cause sparks resulting in loss of vehicle control, serious injury, or even death.

WARNING



Use extreme caution if working under the liftgate during installation. Failure to safely secure the liftgate to the floor extension could cause serious personal injury. Do not remove the lifting device(s) until the liftgate is completely welded onto the truck.



To prevent personal injury, clean up any spilled fluids immediately. To avoid tripping, do not leave tools or components laying around in the work area.



Do not place hands or feet in pinch points.



Do not ride on the platform.



Do not place your feet under the liftgate.



Always use/set the truck's parking brake before operating the liftgate. Failure to follow this recommendation can result in injury.

WARNING



Most accidents involving the operation, maintenance, or repair of products made by Anthony Liftgates occur because the installer/owner/operator failed to observe basic safety rules or operating instructions. Accidents can often be avoided by being alert and recognizing potentially hazardous situations. Any individuals installing, operating, maintaining, or repairing products manufactured by Anthony Liftgates should have the necessary training, skills, and tools required to perform these functions properly and safely. The safety information in this manual serves as a basic guide in an attempt to prevent injury or death.

Anthony Liftgates cannot anticipate every possible circumstance that might involve a potential hazard. The warnings in this manual and on the product itself are, therefore, not all inclusive. If tools, procedures, work methods, or operating techniques that are not specifically mentioned by Anthony Liftgates are used, you must satisfy yourself that they are safe for you and for others. Make sure the liftgate or truck it is mounted onto will not be damaged or made unsafe by any operation, lubrication, maintenance, or repair procedures that you choose.

DO NOT proceed, if any doubt arises about the correct or safe method of performing anything found in this or other Anthony Liftgates' manuals. Seek out expert assistance from a qualified person before continuing.

CAUTION



Many liftgate models provide drivers' steps as a convenience feature. When steps are present, customer-supplied grab handles and other ingress/egress items should be installed.



Even though the Anthony liftgate is easy to install, the installation should be done with at least two people.



Take precautions to avoid welding sparks or the flame from a cutting torch coming into contact with the truck bed's wooden floor or other flammable components.



Tack welds must be strong enough to hold the weight of the individual components being held in place. Insufficient tack welds may not hold the parts in place, resulting in possible bodily harm.

IMPORTANT NOTICE

Use only Penzoil AWX Automatic Transmission Fluid or equivalent in the power unit reservoir. Do not use brake fluid.

Troubleshooting Section

Troubleshooting Guide

Troubleshooting Chart		
Problem	Possible Cause	Possible Solution
Motor does not run when control switch is activated.	Cab cut-off switch.	Turn switch to ON position.
	Dead battery.	Make sure battery is fully charged. Check for loose or corroded battery connections. Replace or recharge battery.
	Circuit breaker.	Reset or replace circuit breaker.
	10 Amp fuse in power unit box.	Replace, if fuse is blown. If problem continues, check for shorts in the electrical system.
	Control box switch.	Check switch using Checking Control Switch procedure in Maintenance section.
	Motor start solenoid.	Check solenoid using the procedure in the Maintenance section.
	Optional power cut-off solenoid.	Check solenoid using the procedure in the Maintenance section.
	Battery cable.	Connect motor directly to a spare battery using the procedure in the Maintenance section.
	Motor.	If the motor is determined to be bad, it should be replaced. Bad motors are typically caused by weak batteries (low voltage), loose connections, corrosion, or a poor ground.
	Circuit breaker.	Reset.
	If liftgate is installed on a semi trailer make sure the battery wire is two gauge or heavier. Smaller wires can reduce the voltage, resulting in motor failures.	
If the motor dose not operate in freezing conditions, make sure the motor housing does not contain water.		

Troubleshooting Chart (continued)

Problem	Possible Cause	Possible Solution
Motor runs, but liftgate will not open or lower to the ground.	Structural damage. Check clearance between platform and dock bumpers.	Fix damage. Replace worn parts.
	Latch pin.	Slide the latch pin to the open position.
	Control switch box.	Check DOWN terminal using the procedure in the Maintenance section.
	Lowering valve solenoid.	Check the solenoid using the procedure in the Maintenance section.
	Lowering valve cartridge.	Check, remove, and clean valve cartridge using the procedure in the Maintenance section.
	Flow control valve.	Remove flow control valve and hook hydraulic hose directly to the cylinder. If the cylinder operates properly, replace the valve.
Motor runs, but platform will not raise will not raise rated capacity, or raises, but drifts down when control switch is released.	Load capacity has been exceeded.	Verify load capacity and adjust load weight.
	Structural damage.	Replace damaged parts.
	Low fluid level.	Fill reservoir.
	Low Voltage.	Inspect the battery connection terminals and check the battery's Voltage (9 Volts minimum).
	Lowering valve.	Solenoid or cartridge may need cleaning or replacement. See Maintenance section.
	Bad piston seals.	See Maintenance section for Checking Cylinder for Leakage.
	Pump relief valve needs adjusted.	See Maintenance section for Checking and Adjusting System Pressure.
Hydraulic pump is worn.	Replace hydraulic pump.	
Sagging platform.	Normal wear. section for Platform Adjustment.	Add shims to platform. See Maintenance
	Bushing wear where lift arms connect to platform.	Replace bushings.
	Structural damage.	Replace worn parts.

Troubleshooting Chart (continued)

Problem	Possible Cause	Possible Solution
Foaming oil.	Air in the hydraulic hose(s).	Check oil level in reservoir.
	Broken or loose fluid return tube.	Remove the oil reservoir and make sure the return tube is below the oil level. If the tube has turned or fallen out, reinstall it into the pump housing. Use a center punch to "stake" the tube into position.
Hydraulic fluid is leaking from packing gland.	Loose packing gland nut.	See Maintenance section for Checking Cylinder for Leakage.
Latch pin is broken or bent.	Operator has lowered platform without releasing latch pin.	The latch pin is only used to prevent the liftgate from opening due to a pressure leak or pressure bleed-off over an extended period of time. Always release latch before opening liftgate.
Liftgate raises truck when lowered to the ground.	Power down system pressure is set too high.	See Maintenance section for Checking and Adjusting System Pressure.
Liftgate will not open.	Platform operating area is not clear.	Clear platform operating area.
	Pin will not slide free.	Activate the "UP" switch and raise the liftgate to the fully stored position. Open the latch pin free.
Platform lowers extremely slow.	Low oil level on power down models.	Fill reservoir.
	Improper oil in hydraulic reservoir.	See Monthly Inspection.
	Bushing wear where lift arms connect to platform.	Replace bushings.
	Damaged or kinked hydraulic hose.	Repair or replace.
	Cylinder rod is scored, pitted, or bent.	Repair or replace.
	Flow control valve.	Remove flow control valve and hook hydraulic hose directly to the cylinder. If the cylinder operates properly, replace the valve.
	Lowering valve.	Solenoid or cartridge may need cleaning or replacement. See Maintenance section.
Platform raises partially and stops.	Load capacity has been exceeded.	Verify load capacity and adjust load weight.
	Structural damage.	Replace damaged parts.
	Low Voltage.	Recharge battery (if less than 9 volts).
	Low pressure.	Refill reservoir. Check pump and motor.
Platform will not lower.	Platform operating area is not clear.	Clear area.
	Structural damage.	Replace damaged parts.
	Low Voltage.	Recharge battery (if less than 9 volts).
	Lowering valve.	See Maintenance section.
	Hydraulic pump and motor.	Replace power unit.



Anthony Liftgates, Inc.
1037 W. Howard Street • P.O. Box 615 • Pontiac, IL 61764-0615
Ph: 815.842.3383 • Fax: 815.844.3612 • Toll Free: 800.482.0003
www.anthonyliftgates.com
